

RUP502-U

RESCUE LIFTING DEVICE

EN 1496:2017/B

Machine Directive
2006/42/EC



Figure 1 - Overview

TABLE OF CONTENTS:

1.	GENERAL DESCRIPTION	1
2.	LOAD LIMIT AND STRENGTH	1
3.	TRANSPORT AND WEIGHT	2
4.	MAINTENANCE AND STORAGE	2
5.	TIME OF USAGE	2
6.	PERIODIC INSPECTIONS	2
7.	TABLE NO. 1 - POSSIBLE INSTALLATION OF DEVICE RUP502-U	3
8.	OVERALL DIMENSIONS	3
9.	MARKING	4
10.	INSTALLATION OF RUP502-U	5
11.	GENERAL SAFETY RULES	6
12.	ESSENTIAL PRINCIPLES FOR USE OF PERSONAL FALL PROTECTION EQUIPMENT	6
13.	WARRANTY	7
14.	IDENTITY CARD	8

1. GENERAL DESCRIPTION

Rescue lifting device RUP502-U can be used as a component of rescue equipment. With use of the device a victim can be ascended from a lower onto a higher level or descended from a higher to a lower level. The descending distance cannot exceed 2 m.



The device can be used to descend personnel above the 2-meter limit by means of an additional WR / CR / CRW retractable type fall arrester to arrest a fall.

BASIC TECHNICAL DATA

Working Load Limit	140kg
Required hand force	44* / 22** kg
Gear ratio	5:1
Lever length	150* / 300**mm
Rope diameter	6.3mm
Weight	20m rope – 13kg 25m rope –

The device RUP502-U is formed by:

- general winch with reel on which work rope of 6.3mm in diameter is wound. The device is fitted with holder UTB (AT017-330),
- for spring-type energy absorber SDW with connectors AZ011,
- removable lever with an option of setting two work lengths (short 150mm / long 300mm).

The device RUP502-U can be mounted on various devices using universal holders. Please refer to Table 1.

2. LOAD LIMIT AND STRENGTH

a) GENERAL INFORMATION

Minimum Breaking Strength (MBS): 20kN.

The device can be loaded with work force along the profile to which it is fixed as shown in Figure 2.

The maximum load that could be transmitted in service from the device to the static construction – 6kN (**The maximum load that could be transmitted in service from the device to the static construction**).

If the device is used as a part of a fall arrest system, the user must be equipped with an element limiting maximum dynamic forces applied on user while arresting a fall to max. 6kN.

b) LIFTING MATERIALS

Working Load Limit (WLL): 500kg

Safety Factor (SF): 4:1.
Available work rope length max.: 25m.

c) LIFTING MATERIALS WITH PULLEY TU415/TU416

Working Load Limit (WLL): 1000kg
Safety Factor (SF): 2:1.
Available work rope length max.: 12m.

d) RESCUE WINCH (PPE)

Working Load Limit (WLL): 140kg
Safety Factor (SF): 10:1.
Available work rope length max.: 25m.



Figure 2 – Permissible load direction

3. TRANSPORT AND WEIGHT

Maximum weight of a complete device (25m rope):
14kg.

Personal fall protection equipment must be transported in a package (e.g.: bag made of moisture-proof textile or foil bag or cases made of steel or plastic) to protect it against damage or moisture.

4. MAINTENANCE AND STORAGE

The device should be cleaned and disinfected without causing adverse effect on the materials which the device is made of. For textile materials (webbings, ropes) use agents suitable for delicate fabrics. Can be washed in hands or in a washing machine. Rinse thoroughly.

Wash textile elements with water only. - If the equipment becomes wet, either when cleaning or in use, allow it to dry naturally, and keep it away from any sources of heat. In metallic products slightly lubricate some mechanical parts (springs, hinges, pawls, etc.) on a regular basis to ensure their better operation.

The device should be stored loosely packed in well-ventilated rooms, protected from direct light, UV degradation, dust, sharp edges, extreme temperatures and aggressive chemical substances.

5. TIME OF USAGE

Maximum time of usage of correctly operating devices is unlimited.

The device must be withdrawn from use immediately and destroyed if it has been used to arrest a fall or there are any doubts concerning its function.

NOTE: Maximum time of usage of the device depends on intensity and environment of use. If the device is used in heavy conditions, being exposed to frequent contact with water, sharp edges, corrosive substances, extreme of temperatures, it may be necessary to withdraw the device after only one use.

6. PERIODIC INSPECTIONS

At least once a year, after every 12 months of use, it is necessary to carry out periodic detailed inspection of the device.

Periodic inspection can be carried out by a properly qualified and skilled person.

After 5 years of use, it is recommended that periodic inspections are carried out by the manufacturer of the equipment or an entity authorised by the manufacturer to carry out such inspections.

7. TABLE NO. 1 - POSSIBLE INSTALLATION OF DEVICE RUP502-U

DEVICE	UNIVERSAL HOLDER
TRIPOD TM1 / TM6 / TM6-T / TM9 / TM9-T / TM9 / TM9-W / TM12 / TM12-2 / TM13 / TM13-T / TM14 / TM15	UTB (AT017-300)
CRANE PAD / LAD	PAD-LAD-UB (PAD100-301-000)
CRANE PSD	PSD-UB (PSD100-131-000)

8. GENERAL DIMENSIONS

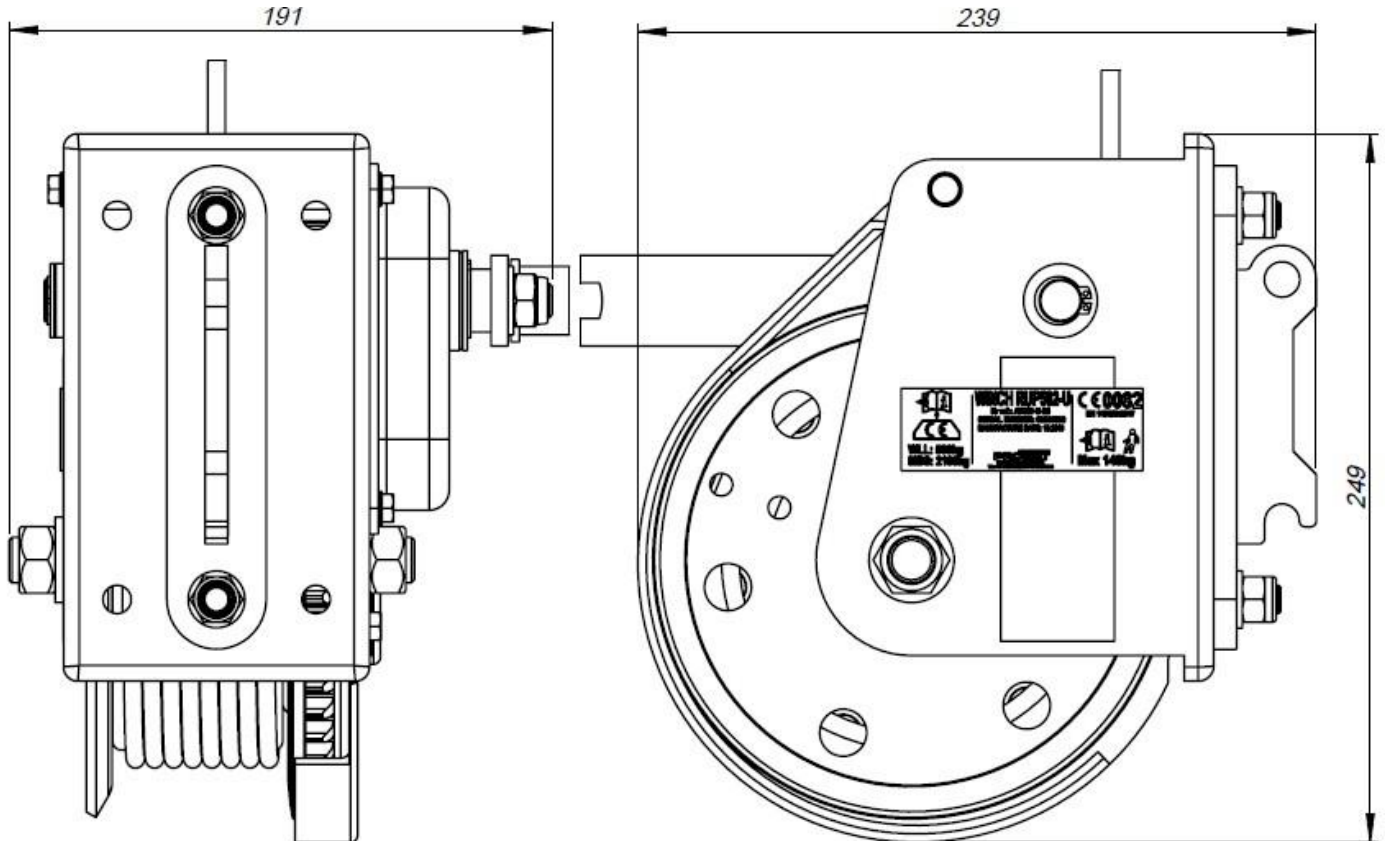

Figure 3 – Overall dimensions of device

9. MARKING

Marking:

- Name/ type of device.
- Device model designation.
- Reference number.
- Number/year/class of European standard.
- CE mark and number of notified body controlling manufacturing of the equipment.
- Month and year of manufacture.
- Serial number of device.
- Attention: read instruction manual.
- Marking of manufacturer or distributor of the device.
- Maximum number of simultaneous users



Figure 6 – “Next inspection” sticker

“Next inspection” sticker should be affixed near identity label and it is necessary to mark month and year of the next periodic inspection. Do not use the device after this date.

Attention: Before the first use, mark the date of next inspection (date of first use + 12 months, e.g. first use 01.2013 – mark 01.2014). “Next inspection” sticker affixed near identity label.



Figure 4 – Identity label of

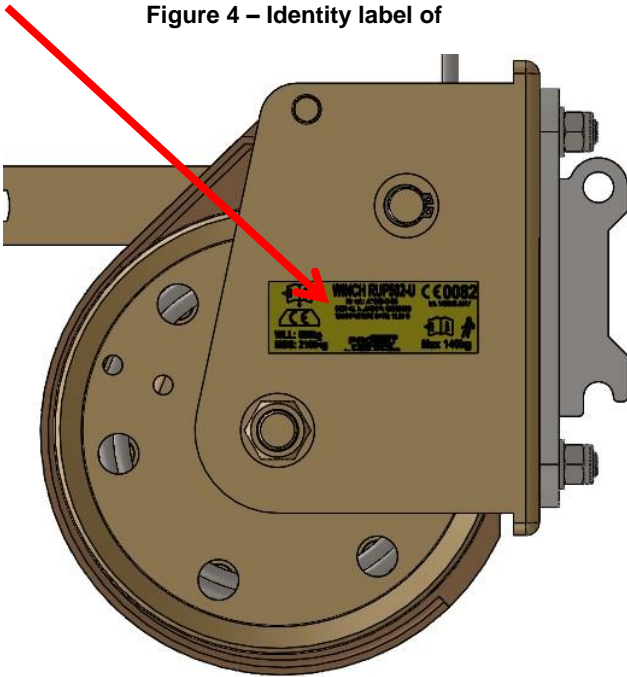
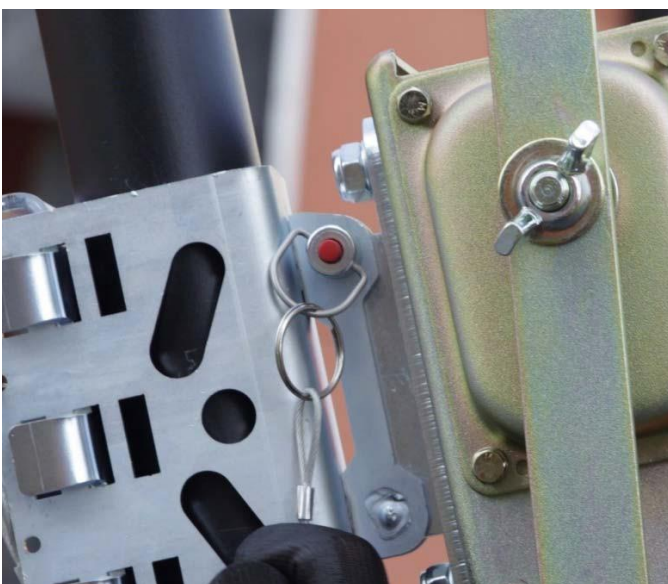

Figure 5 – Location of markings

10. INSTALLING RUP502-U

- a) Install the device in socket of the universal holder and secure with automatic pin.

- b) When using the device for evacuation of personnel (in accordance with EN 1496:2017/B) additionally use energy absorber SDW mounted using AZ011 at the end of work rope.



11. GENERAL SAFETY RULES



**BEFORE OPERATION MAKE SURE
THAT WORK ROPE IS NOT
DAMAGED**



**INSPECT THE FUNCTION OF
FRICTION BRAKE**



**DURING RESCUE USE SPRING-
TYPE ENERGY ABSORBER SDW**

12. ESSENTIAL PRINCIPLES FOR USE OF PERSONAL FALL PROTECTION EQUIPMENT

- For rescue operation with descending use a descender device for rescue compliant with EN 341.
- The device must be used in accordance with instruction manuals of personal fall protection equipment and standards:
EN 361 - full body harnesses
EN 352-3; EN 355; EN 360 - fall restraint devices
EN 362 - connectors
EN 795 / TS16415 - anchor points
- personal fall protection equipment should be used only by personnel trained in its use.
- personal fall protection equipment must not be used by a person with medical condition that could affect safety of the equipment user in normal and emergency use.
- prepare a rescue plan to be implemented whenever necessary.
- it is forbidden to make any alterations or additions to the equipment without prior written consent given by the manufacturer.
- any repair shall only be carried out by manufacturer of the equipment or an authorised representative.
- personal fall protection equipment shall not be used for any purpose other than intended.
- personal fall protection equipment provides individual protection and shall be used by one person only.

- before each use make sure that all parts of the fall arresting system cooperate correctly. Periodically examine connections and fitting of components of the equipment to prevent any accidental loosening or disconnection.
- it is forbidden to use a combination of the equipment where function of any one component is affected by, or interferes with the function of any other.
- before each use of personal fall protection equipment, a pre-use check should be carried out to ensure that it is in a serviceable condition and operates correctly.
- In particular, inspect all accessible elements of the equipment for any damages, excessive wear, corrosion, abrasion, cutting or improper function. For individual devices pay particular attention to:
 - ✓ in full body harnesses and work positioning devices: buckles, regulating elements, attachment points (buckles), webbings, seams, belt loops;
 - ✓ in energy absorbers: attachment loops, webbings, seams, housing, connectors;
 - ✓ in lanyards and textile guides: rope, loops, thimbles, connectors, regulating parts, splices;
 - ✓ in lanyards and steel guides: rope, wires, clamps, loops, thimbles, connectors, regulating parts;
 - ✓ in retractable type fall arresters: lanyard or webbing, retractor and locking mechanism for proper operation, housing, energy absorber, connectors;
 - ✓ in guided type fall arresters: body, proper guiding, locking mechanism for proper operation, rollers, bolts and rivets, connectors, energy absorber;
 - ✓ in connectors (snap hooks): load-bearing body, rivets, main pawl, locking mechanism functionality.
- at least once a year, after each 12 months of use, personal fall protection equipment must be withdrawn from use to carry out periodic detailed inspection. Periodic inspection can be carried out by a person who is responsible for periodic inspections in user's organisation and properly trained in this respect. Periodic inspections can be carried out also by the manufacturer of the equipment or his authorized representative, or an authorized company. Inspect in detail all accessible elements of the equipment paying attention to any damages, excessive wear, corrosion, abrasion, cutting or incorrect function (see the above item.) In some cases, if fall protection equipment has a complex design (e.g. fall arresters), periodic inspections can be carried out by the manufacturer of the equipment, or his authorized representative only. After the periodic inspection, date of the next inspection should be marked.
- Regular periodic inspections are essential in respect of the equipment condition and safety of users which is dependent on functionality and durability of the equipment.

- during periodic inspection it is necessary to check the legibility of all markings on the equipment (identity label of the device).
- all information on fall protection equipment (name, serial number, date of purchase and date of first use, name of user, information on repairs and inspections and withdrawal from use) must be provided in the Identity card of the device. It is responsibility of user's organisation to provide the Identity card and to fill in the required details. The Identity card should be filled in by a person in charge of personal fall protection equipment in user's organisation. It is forbidden to use personal fall protection equipment if the Identity card is not filled in.
- if the equipment is re-sold outside the original country of destination the reseller must provide instructions for use, for maintenance, for periodic inspection and for repair in language of the country where the product is to be used.
- Personal fall protection equipment must be withdrawn from use immediately if any doubts arise in regard of its condition, or proper operation. The equipment must not be used until manufacturer of the equipment carries out a detailed inspection and gives his written consent to use the equipment again.
- Personal fall protection equipment must be withdrawn from use immediately and destroyed if it has been used to arrest a fall.
- full body harness is the only admissible device to be used to support the user's body in personal fall protection equipment.
- in full body harness, to attach a fall protection system use only attachment points (buckles, loops) marked with capital letter "A".

13. WARRANTY

The manufacturer grants a warranty for 12 months from the date of purchase of the device. If a defect is found in any part, the warranty and guarantee period for this part is extended by the time of repairs and effective removal of the defect found.

The warranty covers:

- Defects in material,
- Defects in workmanship,
- Anti-corrosion coating defects

According to the requirements of EN 365 an anchor point shall be subject to periodic inspections carried out at least every 12 months. Periodic inspection shall be carried out by the manufacturer's authorized service point located at the following address:

**PROTEKT Grzegorz Łaszkiwicz
ul. Starorudzka 9
93-403 Łódź**

or person trained in inspections of such equipment.

A trained person is a person who, based on own specialized education and adequate experience, has sufficient knowledge in installed protective and rescue equipment, and is familiarized with applicable HSE regulations, guidelines and generally acknowledged technical rules to such extent that he is able to assess safety of use and correct application of safety devices.

Before each use of the system check whether date of the next inspection is not expired. Do not use the device after this date. Before each use of the system visually

check the system for its integrity and technical condition and whether steel cable is tensioned.

If any defect or lack of integrity is found, do not use the point.

If any doubts arise as regards the use of the equipment, please contact the manufacturer and never repair the equipment on your own!

A system which has been used to arrest a fall must be withdrawn from use immediately!

The system which has been used to arrest a fall can be admitted for use again after a detailed inspection is carried out by the manufacturer or an authorized service point.

When using the system, pay special attention to risks affecting operation of the personal fall protection equipment or the user's safety, and in particular to kinks and rope movement on sharp edges, oscillatory falls, electricity, influence of extreme temperatures, equipment damage, adverse environmental factors, chemical substances and contamination.

Neither modify, repair components of the system nor replace them with non-original spare parts.

14. IDENTITY CARD

IDENTITY CARD (compliant with EN365)					
Reference number of	RUP502-U	Serial number:		
Date of first use (installation)	Date of manufacture:		
Place of installation				
User name:				
Inspection and repair record					
No.	Date of inspection	Type of inspection / repair	Remarks	Date of next inspection	Name and signature of service technician
1					
2					
3					
4					
5					
6					
7					
8					
9					
10					